

Hall

FOOD EQUIPMENT

Mincer Mixer 40MM



Since 1945

Standard inclusions:

- 1 x 3 mm Mince Plate
- 1 x 5 mm Mince Plate
- 1 x 10 mm Mince Plate
- 1 x Knife Holder
- 2 x Insert
- 1 x Worm Puller
- 1 x Cleaning Brush

Smart by Design, Built to Last



Smart by Design, Built to Last

Hall Food Equipment is an Australian owned and operated company and has been manufacturing Butchery Machines in Sydney since 1945. During this time we have successfully expanded our range of Australian made food processing equipment to include Mincers, Sausage Fillers, Mincer Mixers, Burger Press, Chopping Blocks, Preparation Tables & Pickle Pumps.

We pride ourselves on applying smart design, with quality built, durable high finished machines that will last for many years. We give personal attention to all our customers. Our Customer Service aim is to meet and exceed customer expectations through our quality products and true old fashioned customer service.

Intelligent design, and decades of experience are combined with a quality finish to produce the Hall Food Equipment Mincer Mixer. Hall Mincer Mixer will reward you by mincing and mixing meat and a variety of other products quickly, consistently and efficiently without the need for preservatives to make the product look and remain appealing.

Hall Mincer Mixer is a no compromise machines that comes standard with a stainless steel Barrel, stainless steel Worm and stainless steel Lock Ring. The hopper/tub has a high quality polished stainless steel finish to ensure that mince will not stick to the machine. The surface is easy to clean and is hygienic.

Hall Mincer Mixer is extremely versatile and can be used for a variety of different applications, including mincing & mixing all meat types, cheese, fruits, vegetables and nuts.

Hall Mincer Mixers complies with FSANZ, HACCP standards and is AS/NZS & AQIS Certified.



Polished Tub & Mixing Paddle
Removable Stainless Steel Paddle



42 Size Cutting Head
with 42 Size Worm



Stainless Steel Casters with Locks



Visually appealing & Long Shelf Life Mince without preservatives



Smart by Design, Built to Last

The highly polished interior hopper and the efficient and removable Mixing Paddle of the Mincer Mixer stops mince sticking to the machine resulting in less wasted product, and easier, quicker clean and better hygiene. The bottom line is more profit to the operator from a higher yield, reduced time to clean and a visually appealing & longer shelf life mince. These features are sure to please every quality & efficiency conscious operator and most importantly their customers. Hall Mincer Mixer has two high quality independent electric motor driven reduction gear boxes - one to drive the mixing paddle and the other to drive the mincer worm. The high efficiency motors and quality gear boxes ensure economical, efficient and quiet operation for many years.

Hall Mincer Mixer does not compromise on quality & safety. A stainless steel lid is designed for easy & safe operation. It provides good visibility. The Stainless Steel lid can be cleaned with a hose quickly and easily.

The lid has a safety latch to prevent accidental opening while machine is running, ensuring safe operation. The lid is also fitted with a safety cut out switch which stops the machine automatically if the lid is lifted during operation.

Unlike machines with dull/bead /sand blasted finish on the side covers, Hall Mincer Mixer are fully polished for easy clean. Meat and other product won't get stuck onto machine, reducing the chance of foul odors and smells from unseen / hard to reach mince.

Easy Clean = Better Hygiene

Hall Food machinery is very Reliable & Durable and given a bit of care will run trouble free for many years. All consumable parts & spares for our machines are reasonably priced & is readily available to minimise the cost of machine maintenance & down time.

Compare our quality, customer service, spare parts prices and availability with other makes of machine and you would realise the benefit of choosing TRUSTED HALL FOOD EQUIPMENT.

Contact us for a list of un-biased Hall Equipment users in your region/state.



Stainless Steel Lid with Safety Interlock

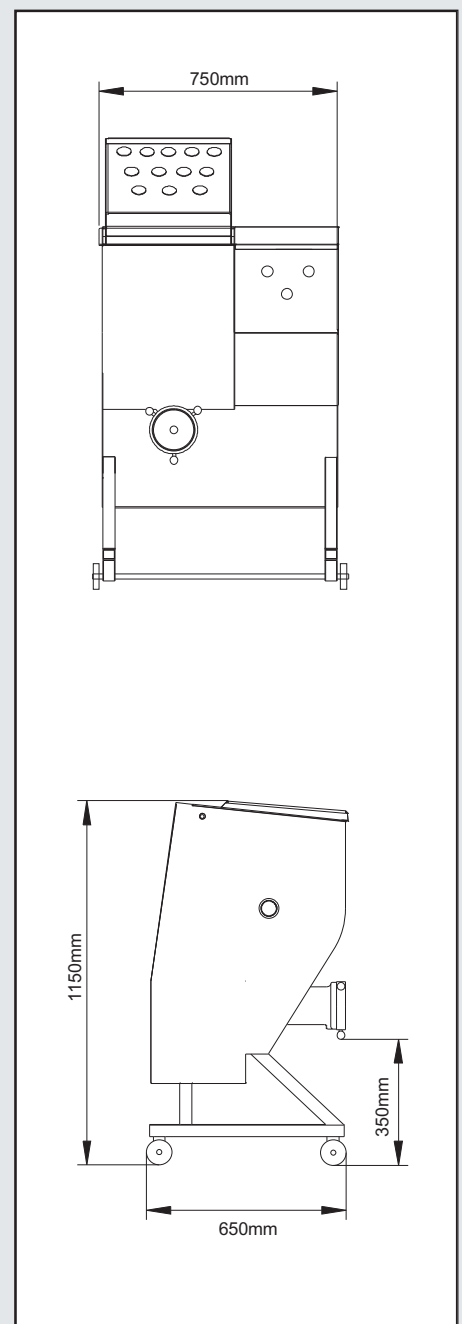

FEATURES

- ☞ Stainless Steel Body
- ☞ Stainless Steel Worm
- ☞ Stainless Steel Lock Ring
- ☞ Stainless Steel Exterior Skirt
- ☞ Stainless Steel Legs
- ☞ Stainless Steel Drive Shaft
- ☞ Stainless Steel Mixing Pedal
- ☞ Flawlessly Smooth, Polished Stainless Steel tub
- ☞ Removable Stainless Steel mixing arm for easy cleaning
- ☞ Built in Motor Overload Protection
- ☞ 24 Volt Control circuits for additional user safety
- ☞ Ergonomic design, requires minimum of floor space, can be easily wheeled through standard door
- ☞ Supplied with 4 swivel lockable stainless steel castors
- ☞ Stainless Steel Lid with clear visibility
- ☞ Advanced Safety Cut out Switch and Safety Latch on Lid
- ☞ Supplied with complete Cutting package including 3 Plates, 2 Blades, 1 Knife, Worm Puller & Cleaning Brush
- ☞ Reduces labour cost
- ☞ Low tub filling height
- ☞ Easy to clean – no visible bolts on side skirts – no place for meat to stick or hide
- ☞ Genuine full Single Cut 42 Size Cutting System with 42 Size Worm to give best cut and high efficiency, not like some other machines with 32 Cutting Head
- ☞ Full 42 Size worm to handle more meat with each turn hence less bruising, minimal rise in temperature of the meat, higher yield & longer shelf life of the mince
- ☞ Electro polished Body, Worm & Lock Ring for efficient cool cut ensuring maximum product shelf life
- ☞ Electrical parts are enclosed in an IP 65 standard watertight box for safety
- ☞ 3 meter heavy duty power lead

TECHNICAL SPECIFICATIONS

Length	750mm	Weight	200kg (packed)		
Height	1200mm	Ship Size	1200x1200x1360mm		
Width	750mm	Mix motor	0.75 kW		
Fill height (tub height)	1100mm	Mince Motor	3.0 kW		
Power requirements	415v 15A 50Hz, 3 Phase	Tub Capacity	80 L	Mix Capacity	40kg
Full Load	15.0A	Cutting package	3mm, 5mm & 10mm plates, 2 blades, 1 knife & worm puller		

OPTIONAL EXTRAS (must be specified with order)

- Full range of knives and plates
- Foot Paddle Switch for hands free operation
- Single Phase option available - 240v 16A, 50Hz, 30A point minimum.

Specifications are subject to change without notice.



Manufactured and distributed by:-
Hall Food Equipment

Phone (08) 8417 6000
Fax (08) 8417 6001

www.mblsa.com.au
Email orders@mblsa.com.au

Contact us for a list of un-biased Hall Equipment users in your region/state.